

DELUXE PGOLA FREE STANDING

INSTRUCTION MANUAL.

3.6×7.2
ELE+LED

We appreciate your purchase of our Pergola.

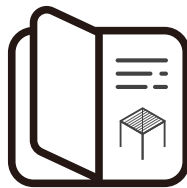

Instruction Manual

This guide will give you step-by-step instructions on how to assemble and care for your pergola, ensuring it lasts for years of enjoyment and reliable use.

Be sure to follow all steps carefully, as incorrect installation may result in serious injury.

IMPORTANT:

Warning: Safety Instructions

For the safety of individuals, it is crucial to follow these instructions. Please retain them for future reference.

Children and individuals with disabilities or limited experience may use the appliance if they are properly supervised or trained and understand the potential risks.

Children should not be allowed to play with the appliance. Cleaning and maintenance tasks should only be performed by children under supervision.

This pergola is designed for outdoor residential use, providing protection from direct sunlight, glare, and heat.

Any use or modification not outlined in this manual is considered improper and could pose significant risks to both users and property. Such actions will void the product warranty.

BEFORE THE INSTALLATION

PREPARE ALL THE NECESSARY TOOLS

To assemble your pergola properly and safely, make sure you have the following tools and accessories on hand, as these are not included.

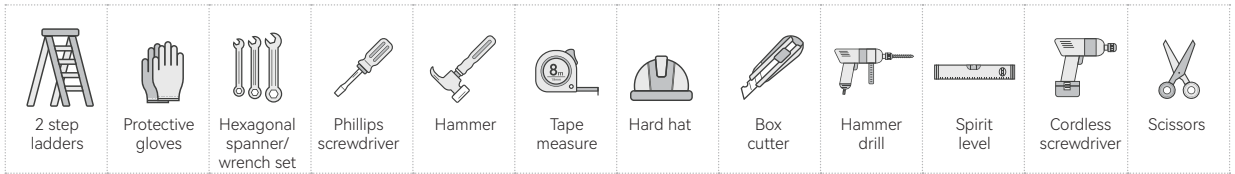

CHECK FOR MISSING PARTS:

Before starting the installation, verify that you have all the necessary parts to assemble your e-Motion. Double-check that the quantity of parts matches the model you purchased.

If any parts are missing, please reach out to customer service before proceeding with the installation.

PREPARE THE PARTS FOR EACH STEP:

In the Installation section of the manual, each step specifies the parts and quantities needed. We recommend gathering the necessary parts ahead of time for each step. This will help save you time and make the assembly process smoother. To avoid damaging the painted surfaces, place the parts on cardboard or another soft surface if possible.

CHOOSE AN APPROPRIATE LOCATION:

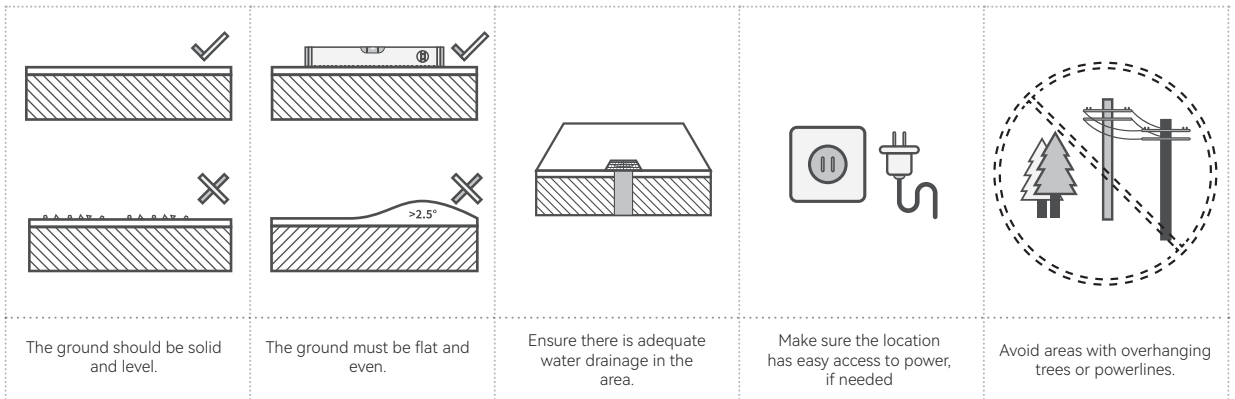

WARNING:

Many terraces or patios are built with a slight slope to direct rainwater away from the house or other structures. For proper pergola installation, a completely level surface is required. Small pebbles or uneven ground may prevent the pergola from being securely anchored.

If the pergola is installed on an uneven surface, it may affect the performance of accessory components and could void the product warranty. You may also need to adjust the height of the pillars for proper installation.













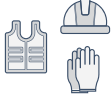



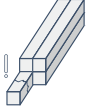
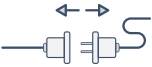
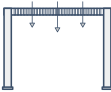
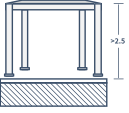

PREPARE THE FOUNDATION:

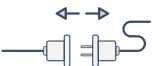
To get your foundation ready, make sure to:

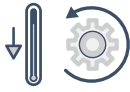
- Check for underground pipes and cables (call local relative authorities before digging).
- Verify with local authorities if any building permits are necessary.
- If you're opting for a concrete base, consult with a reputable contractor.

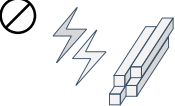
IMPORTANT SAFETY SUGGESTIONS

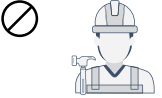
To ensure the safety of everyone involved in the installation and use of the pergola, it is essential to follow the safety guidelines listed below.

	The pergola must be placed and secured on a flat, level surface.		Always wear suitable work shoes, gloves, and eye protection during assembly.
	When using power tools or a ladder, always adhere to the manufacturer's safety instructions.		Always wear protective gear to minimize the risk of injury in case of a fall.
	Ensure the pergola meets local building regulations and codes.		Do not step on the louvers.
	Use only ladders and scaffolding that can support the required weight.		Visually inspect the pergola for damage prior to each use. If damage is detected, stop using it immediately and reach out to authorized personnel to fix it.
	Remove any excess cords and disconnect any non-essential equipment before installing the drive.		To avoid damage, set the louvers in the vertical position during snow or windy conditions.
	Unprotected moving parts that pose a hazard should be installed more than 2.5 meters above the floor or any surface that could allow access to them.		Always use replacement parts that are approved by the manufacturer.
	To avoid damage to the pergola, ensure that foliage or foreign objects on the louvers and in the guide rails are removed frequently.		Only certified personnel are authorized to carry out electrical installation, following the relevant regulations
	Disconnect all electrical connections from the mains prior to installation.		Operate the pergola remotely only when you can see the moving parts clearly.
	Only a licensed electrical contractor should install the power sources for electric pergolas.		If the motor undergoes repeated open-close cycles, it may enter overheat protection mode and will return to normal once it cools down.
	Keep children and pets away from the assembly area until the installation is fully completed.		Dispose of all plastic bags responsibly and keep them out of reach of children.
	Keep a safe distance from power lines, especially when handling metal parts.		Avoid assembling the pergola in windy or wet conditions.
	In the event of a damaged supply cord, only the manufacturer, a service agent, or similarly qualified personnel should replace it		Do not store hot items, such as recently used grills or blowtorches, under or near the pergola.

	To prevent damage to the louvers' drive, do not operate the roof mechanism in the presence of frost or ice.		Keep clothing and body parts clear of the pergola to avoid them becoming caught in the moving parts.
	Keep items off the louvers.		It is not allowed to hang objects on the pergola, as it may result in serious damage.
	Before making any modifications to the design or configuration of the equipment, consult the manufacturer or an authorized representative.		Keep children away from the fixed controls and ensure remote controls are out of their reach.
	The warranty will be voided, and the operating mechanism may be damaged if non-original branded accessories are installed.		Important: Regularly clean the columns' drainage holes with a soft brush to prevent blockages and damage.
	We guarantee the resistance of the pergola for winds up to 80km/h		We guarantee the resistance of the pergola for a maximum snowweight of 50kg/m2

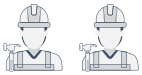

2 PERSONNEL REQUIRED

Electric control system are in the cavity of the post.

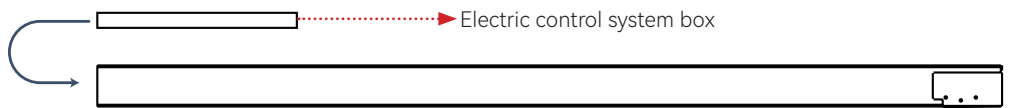

Connecting bar & brush are in the cavity of the beam.



There is a Product Tracking Number in the inner side of the carton (see below diagram). For better and efficient after-sales in the future, when tear down the carton box, please take a photo of the Tracking Number and save the photo.

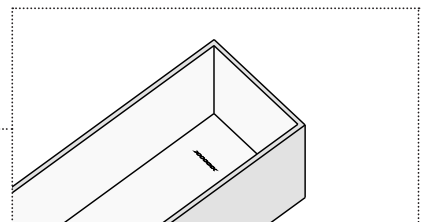
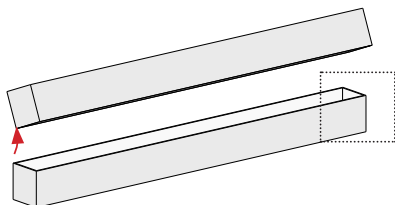

PERGOLA SIZE

3.6X7.2

Plan Size

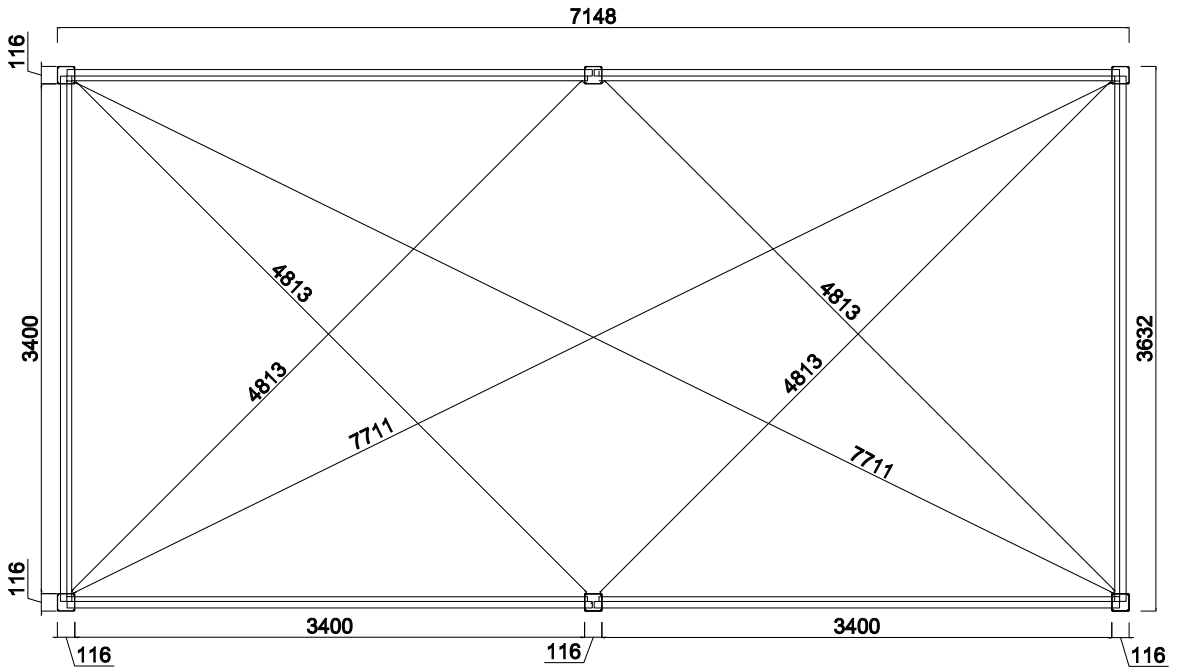

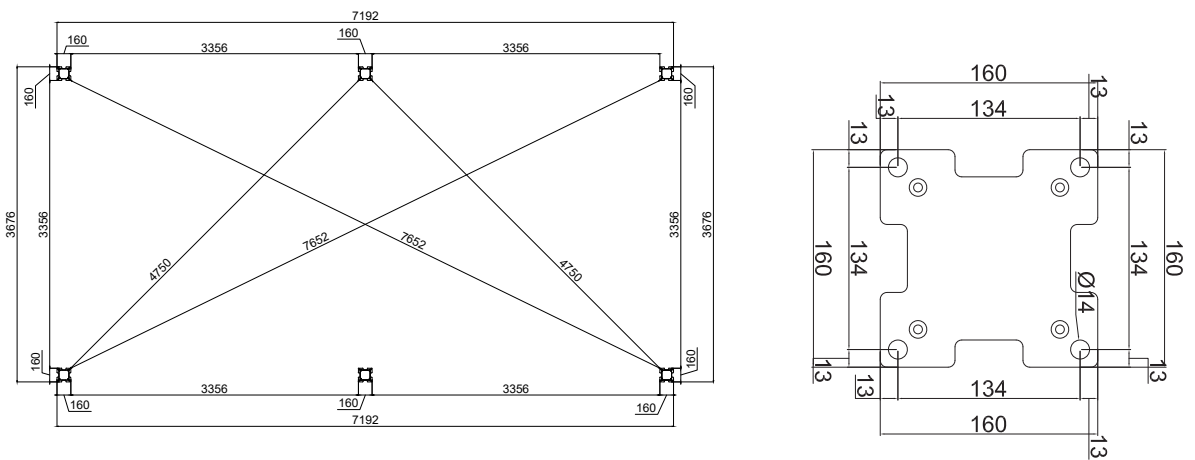

Base Plate Layout Plan







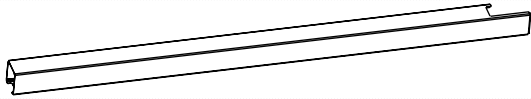

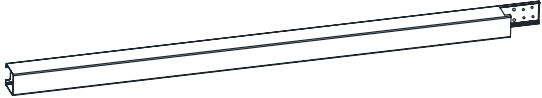
SPARE PART LIST



3.6X7.2

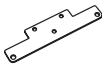



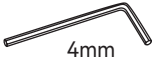

CARTON 1/9

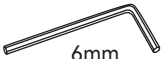

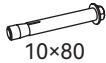

No.	Profile	Diagram	Size	QTY
AO			116X116 L=2550mm	2
AO-3			116X116 L=2550mm	1

No.	Diagram	QTY
IO		3
JO		3

No.	Diagram	QTY
QO	 6mm	36
EO-1		2
RO		36
SO		92
UO	 lock nut	46
UO-3	 M14	2

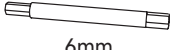
No.	Diagram	QTY
ZO-1	 4mm	1
ZO-2	 4mm	1
ZO-3	 6mm	1





No.	Diagram	QTY
TO	 10x80	12
XO-1	 6x35 4mm	12
UO-1	 plastic nut	46
VO		138
WO-1	 5x19 5mm	6
XO-2	 6x20 4mm	46
XO-3	 6x16 4mm	4

No.	Diagram	QTY
ZO-4	 6mm	1
ZO-5	 10mm	1
ZO-6	 PH2	1
ZO-7	 8mm	1



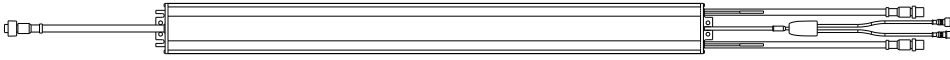
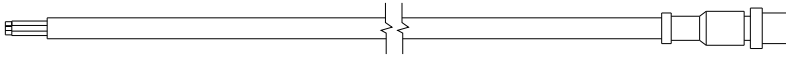

SPARE PART LIST





3.6X7.2



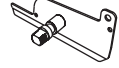
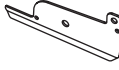

CARTON 1/9

No.	Diagram	QTY
E-A1		1
E-B		1
E-BR		1
E-D		1
E-E		1





CARTON 2/9

No.	Profile	Diagram	Size	QTY
AO-2			116X116 L=2550mm	2
AO-3			116X116 L=2550mm	1





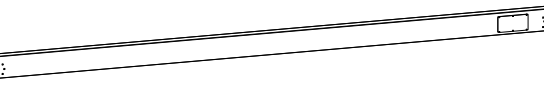

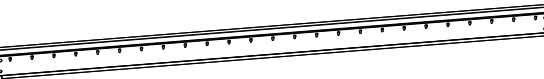

No.	Diagram	QTY
KO		2
LO		44
LO-1		46
VO		90
XO	 6x40 4mm	90

No.	Diagram	QTY
MO		90
MO-1		90
WO	 4x16 PH2	184
UO	 lock nut	90

CARTON 3/9

No.	Profile	Diagram	Size	QTY
B3			75X195 L=3503mm	1
B4			75X195 L=3503mm	1
BO-4			75X195 L=3503mm	2

CARTON 4/9

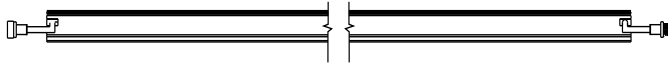

No.	Profile	Diagram	Size	QTY
CO-3			75X195 L=3503mm	1
CO-4			75X195 L=3503mm	1
EO			64X111 L=3464mm	1
FO			27X8 L=3348mm	2

No.	Profile	Diagram	Size	QTY
LED1			69X78 L=3399mm	6



CARTON 5/9

No.	Profile	Diagram	Size	QTY
GO			166X38 L=3464mm	9



CARTON 6/9

No.	Profile	Diagram	Size	QTY
GO			166X38 L=3464mm	9

CARTON 7/9

No.	Profile	Diagram	Size	QTY
GO			166X38 L=3464mm	9

CARTON 8/9

No.	Profile	Diagram	Size	QTY
GO			166X38 L=3464mm	9

CARTON 9/9

No.	Profile	Diagram	Size	QTY
GO			166X38 L=3464mm	10

Before proceeding with the assembly of your louvered pergola, it is necessary to check that all parts listed are supplied and not damaged.

Any missing part must be reported within 10 days of delivery.

Do not discard the packaging without ensuring that the product is functioning properly.

Attention:

Please note that the outlet on the skirt should be in the front position for the front side, while for the rear side, the outlet is a mirror image of the front face.

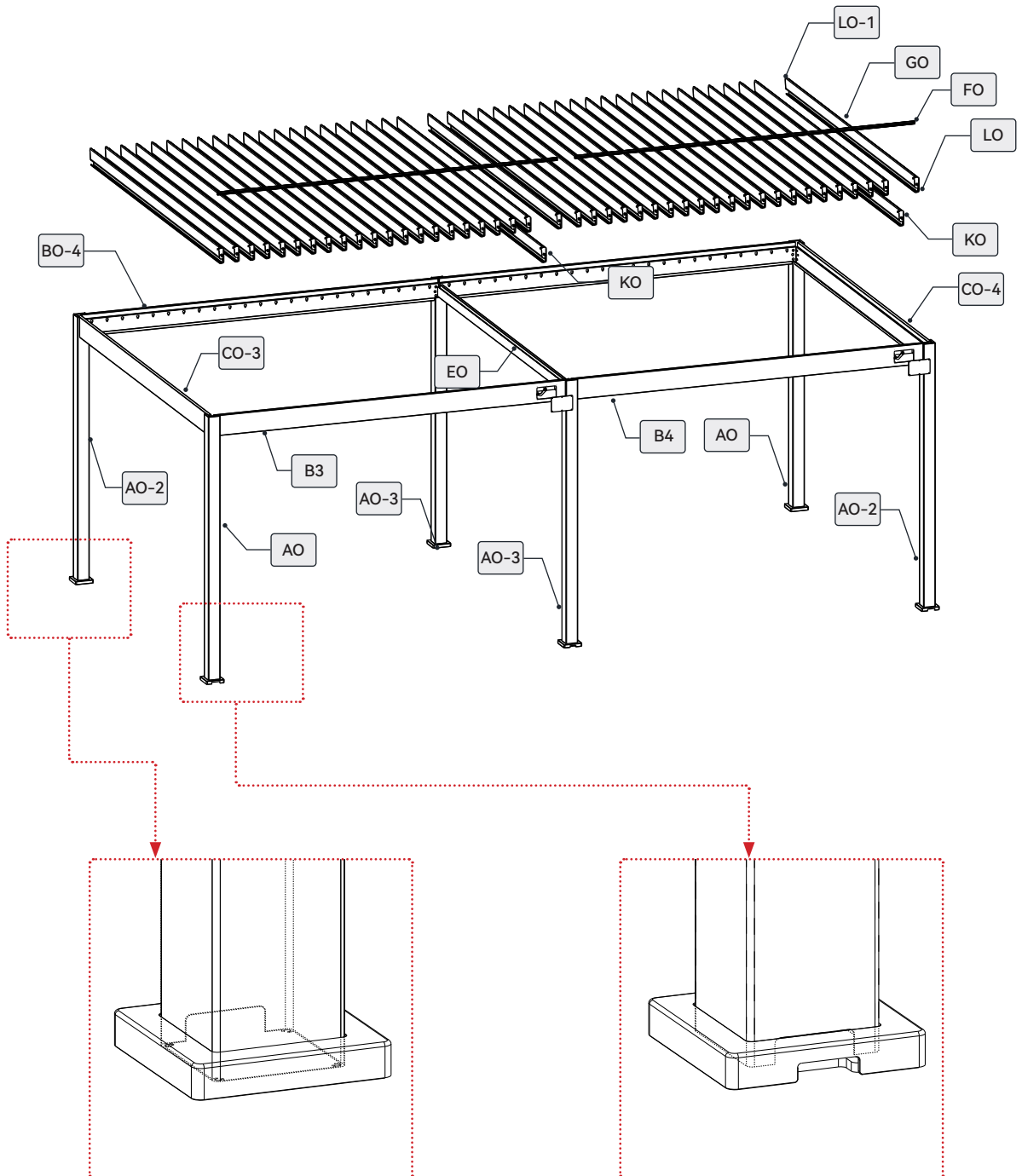

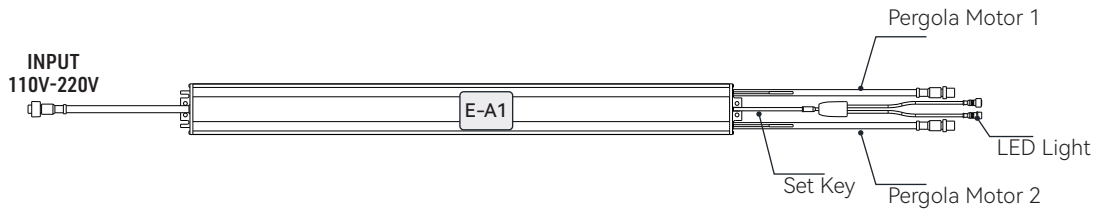

Cable Diagram

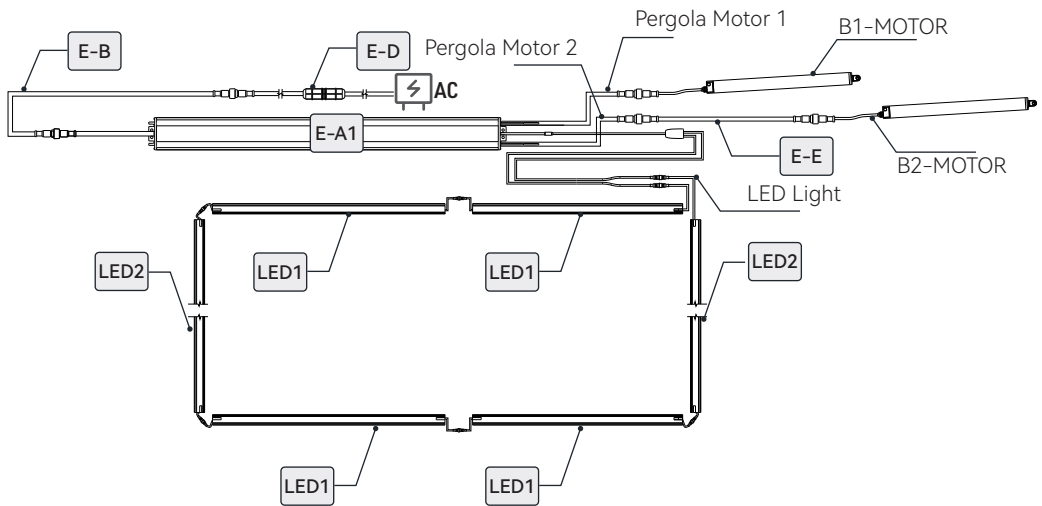

Attention:

1. The controller must be installed inside the side beam, with the input cable routed through the post and exiting through the drainage opening.
2. Insert the controller at least 20 cm deep into the recess of the side beam, ensuring a distance of 40 mm from the end of the beam.
3. The accessories (such as Sunblinds or Panels) are secured by screwing it into the beam, 18 cm from the end of the beam.

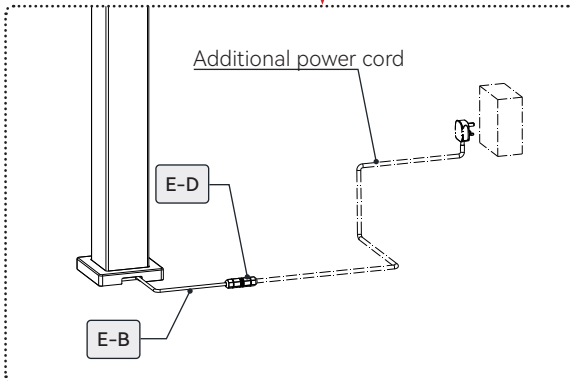
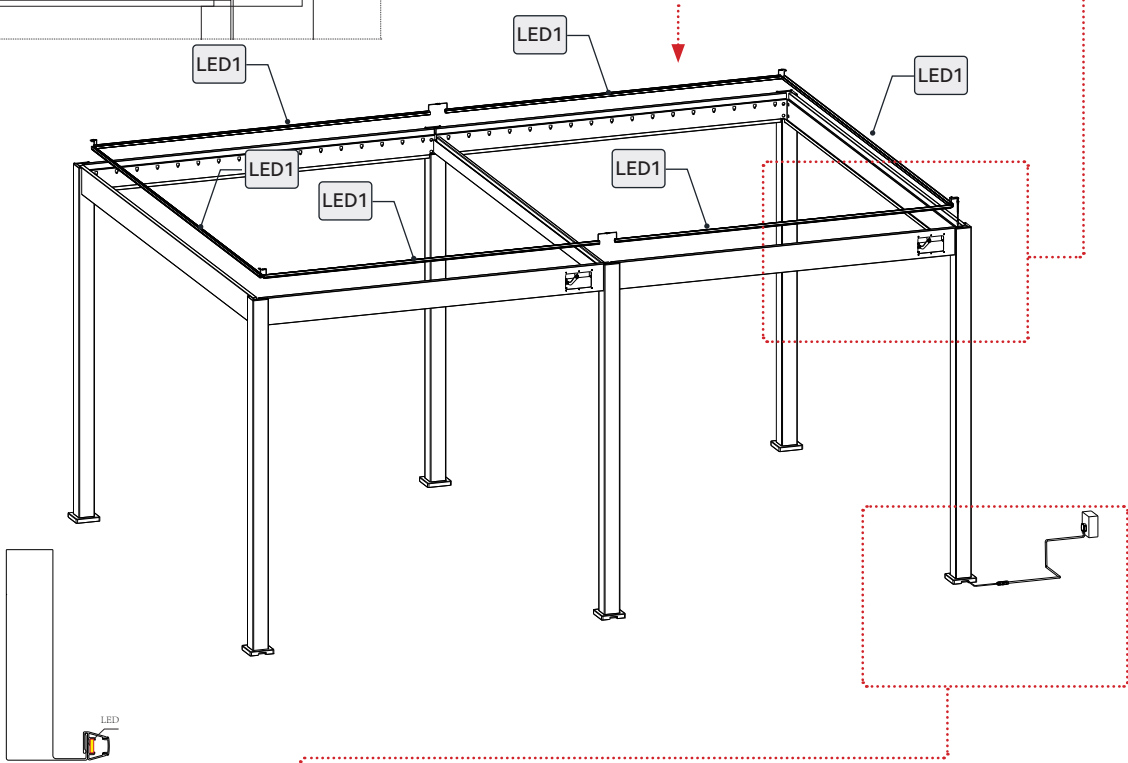
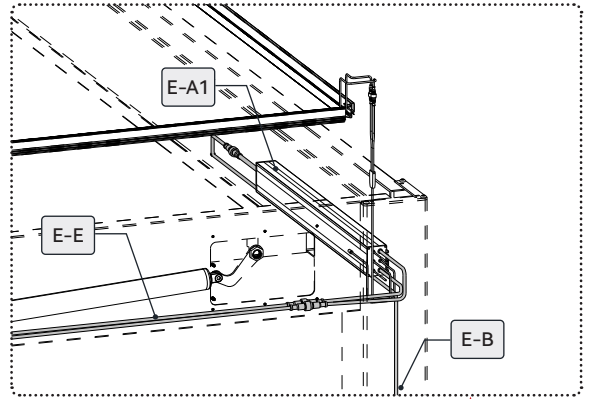
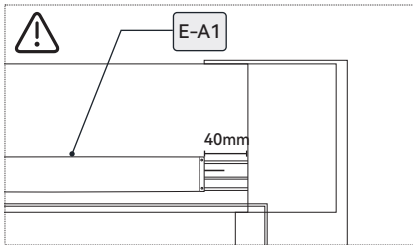



Attention:



Please select the appropriate power cord based on the country you are in, and connect it using a waterproof connector. This controller can support voltages ranging from 110V to 220V.







There are 3 cables at the input end of the power, namely:
 Brown: LIVE WIRE
 Blue: NEUTRAL WIRE
 Yellow & Green: EARTH WIRE

The illustration uses a manual wrench, which can be replaced with an electric P-tip.

KO		2
LO		44
LO-1		46

MO		90
MO-1		90
VO		90

XO		90
UO		90

ZO-1		4mm
ZO-2		4mm
ZO-5		10mm

Attention:

Install the spindles for the cover on two ends of the louvers.

Note: To avoid any broken of the plastic parts(MO), when use the pistol drill, please reduce the twisting force of it .



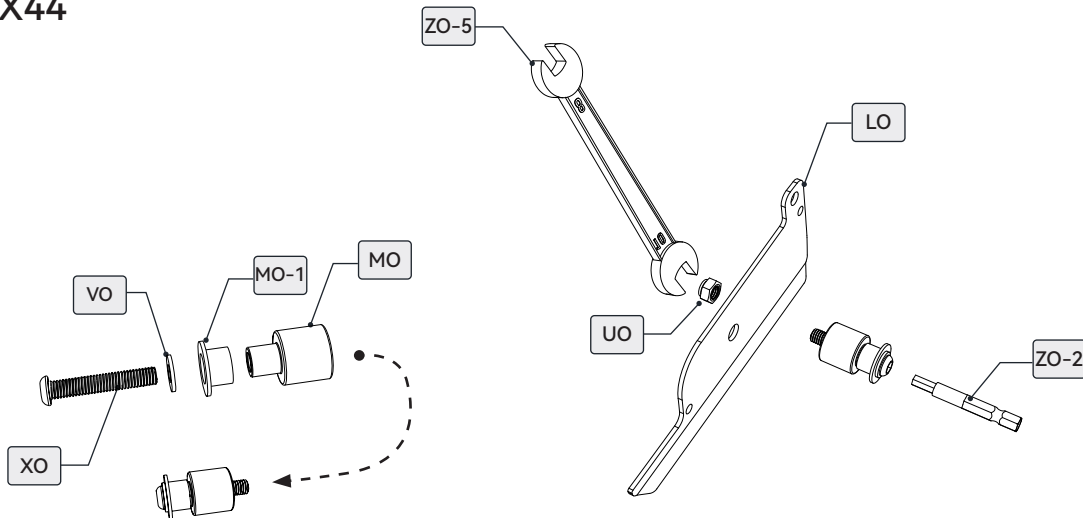

X44

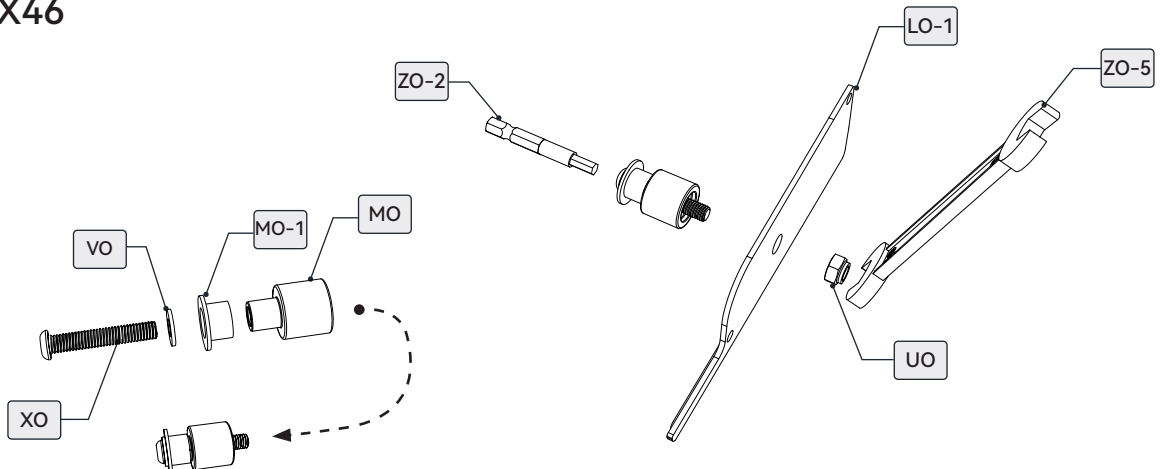

X46



Install the louvre cover on two ends of the installed louvres and the spindle louvre.

GO		46	WO		4x16		PH2	184	ZO-6		PH2
----	---	----	----	---	------	---	-----	-----	------	---	-----

X2

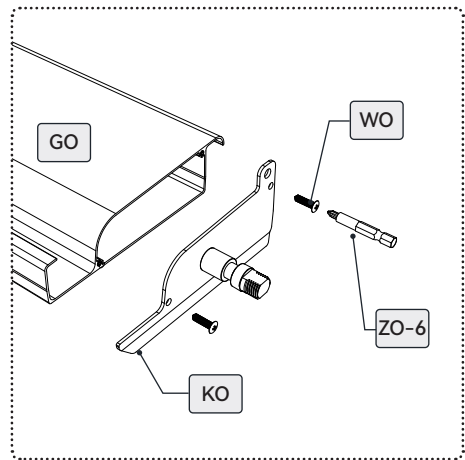
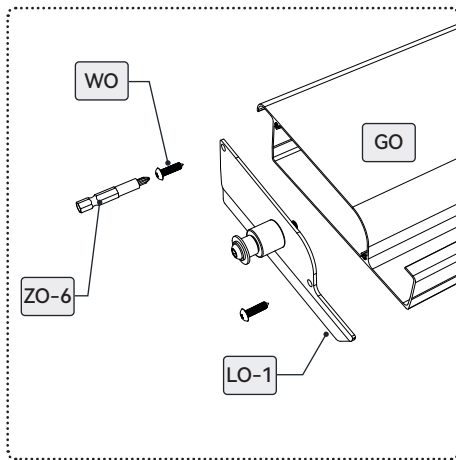

X44

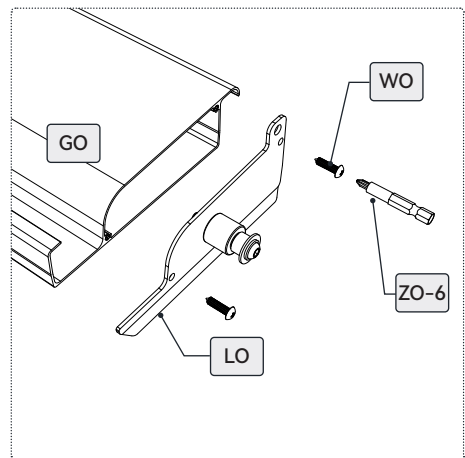
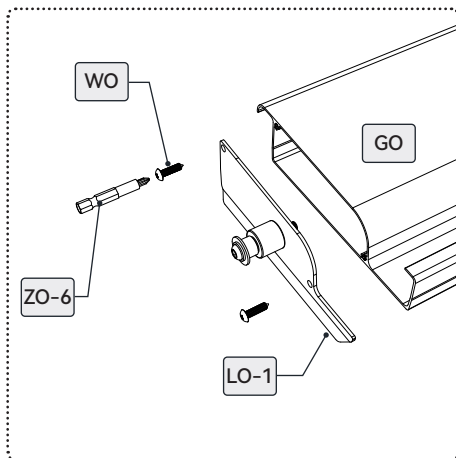

First, connect the input end of the controller to an extension cable, then pass the extension cable through the upright and out from the drainage hole to prevent interference with the subsequent installation of the base plate.

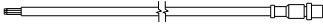

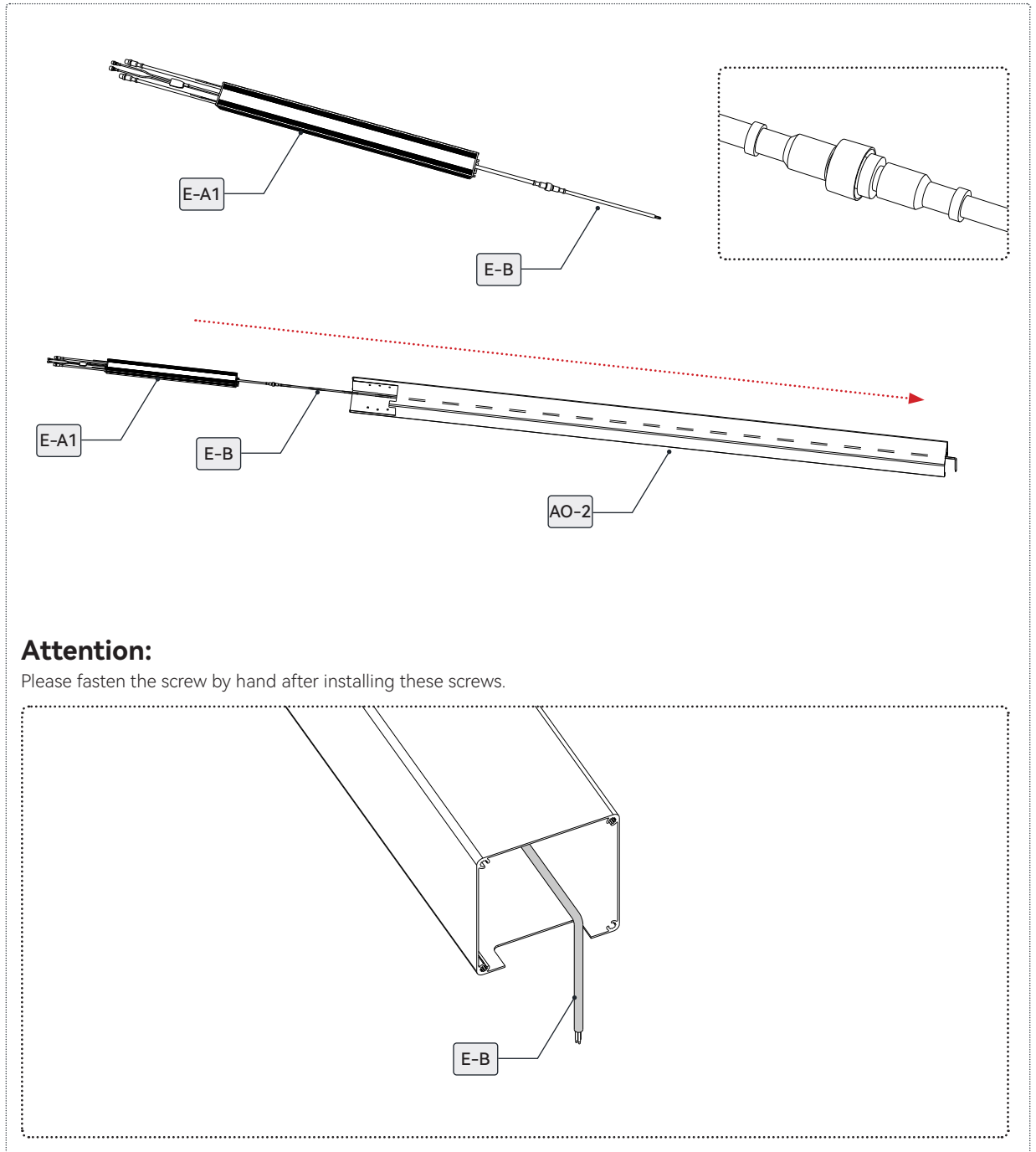





E-A1		1
E-B		1



Attention:

Please fasten the screw by hand after installing these screws.

1. Install the post skirt first
2. Make sure the outlet of the skirt and the post are on the same face

AO		2	IO		6	XO-1		24	ZO-1		4mm
AO-2		2	JO		6				ZO-2		4mm
AO-3		2									

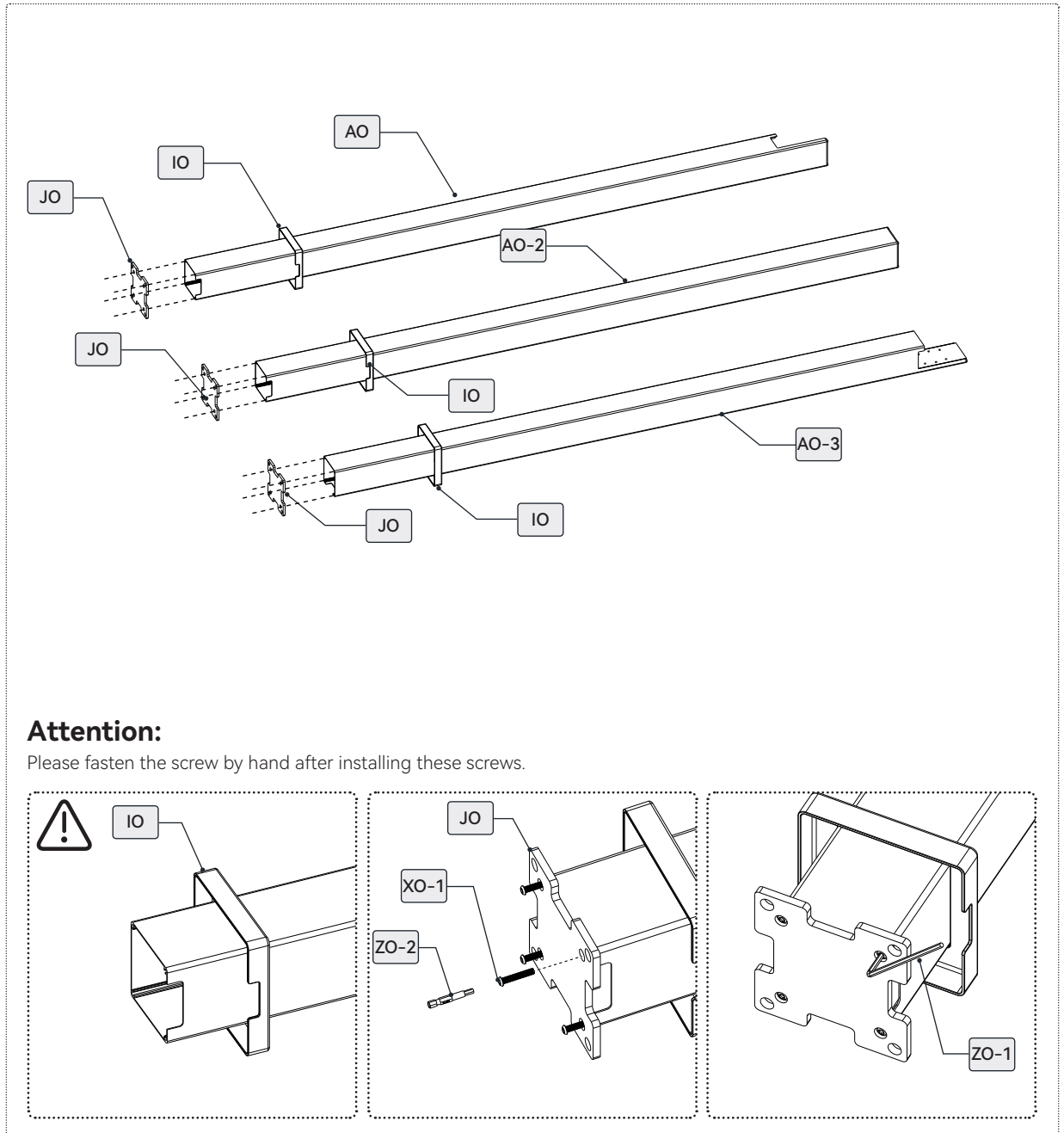



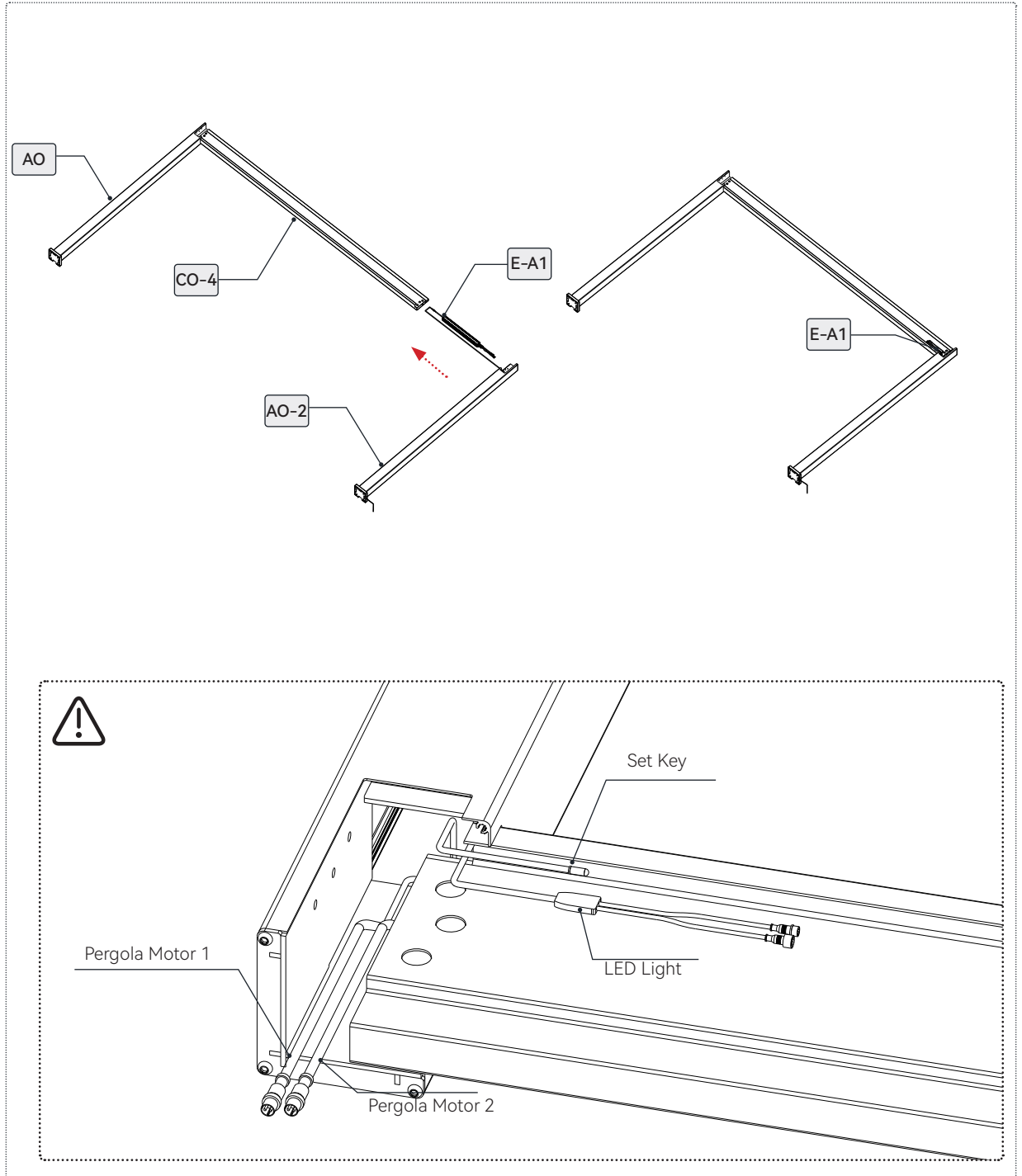

Route the appropriate output cables of the controller to facilitate later installation. Ensure that the E-A controller is positioned correctly—at least 20 cm deep from the end of the beam.

CO-4		1
------	---	---



Install the screws for the side beams.

CO-3		1	QO			12	ZO-1		4mm
							ZO-2		4mm

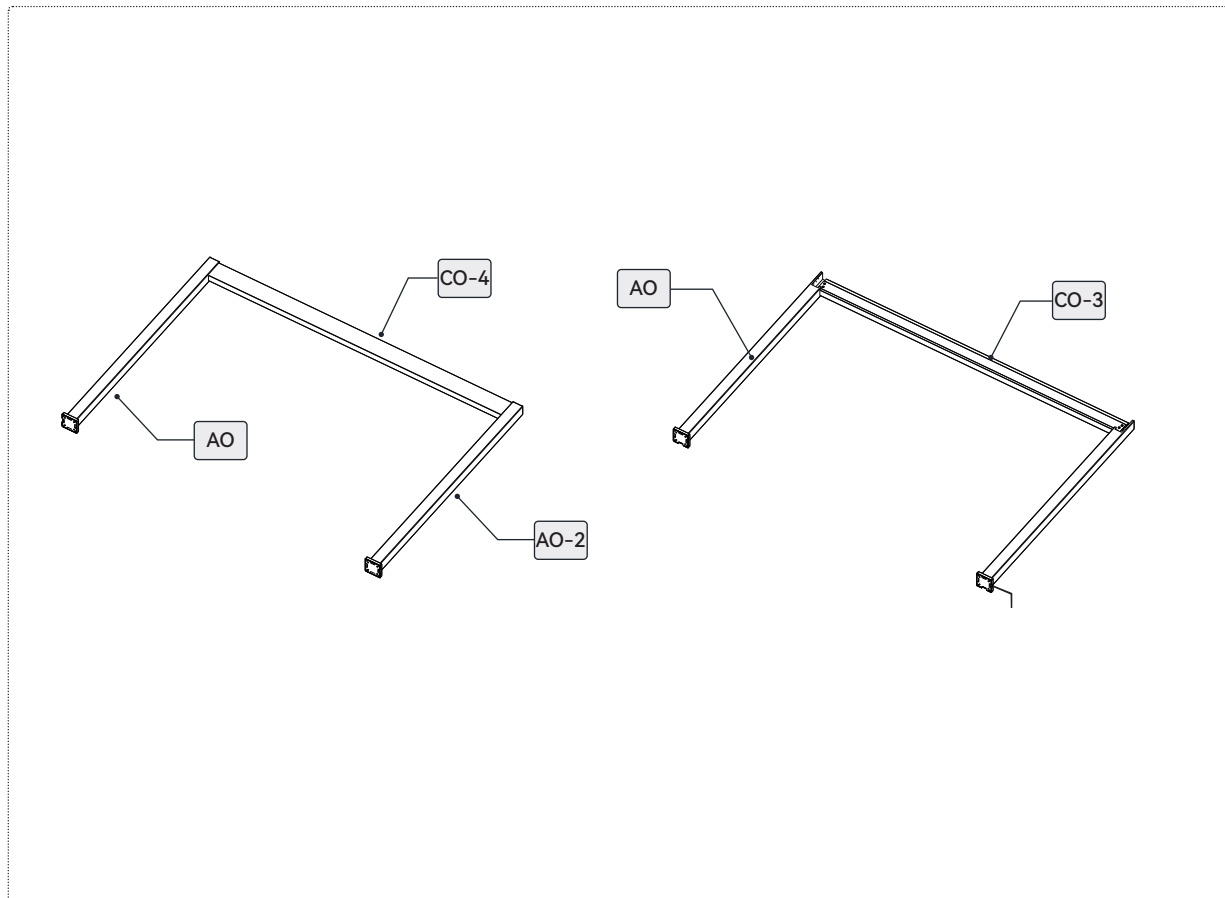





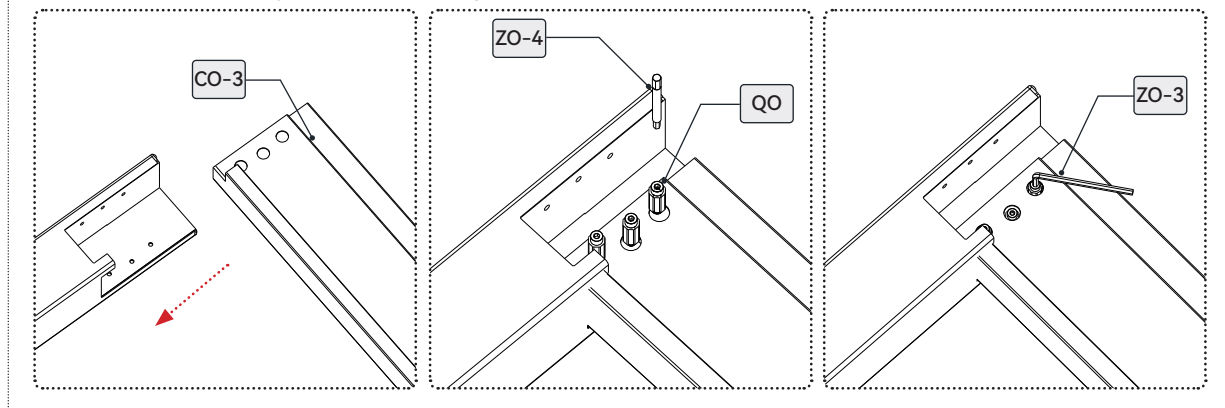

Attention:

Please fasten the screw by hand after installing these screws.



Install the basic framework.

B3		1	QO			18	ZO-1		4mm
BO-4		2					ZO-2		4mm

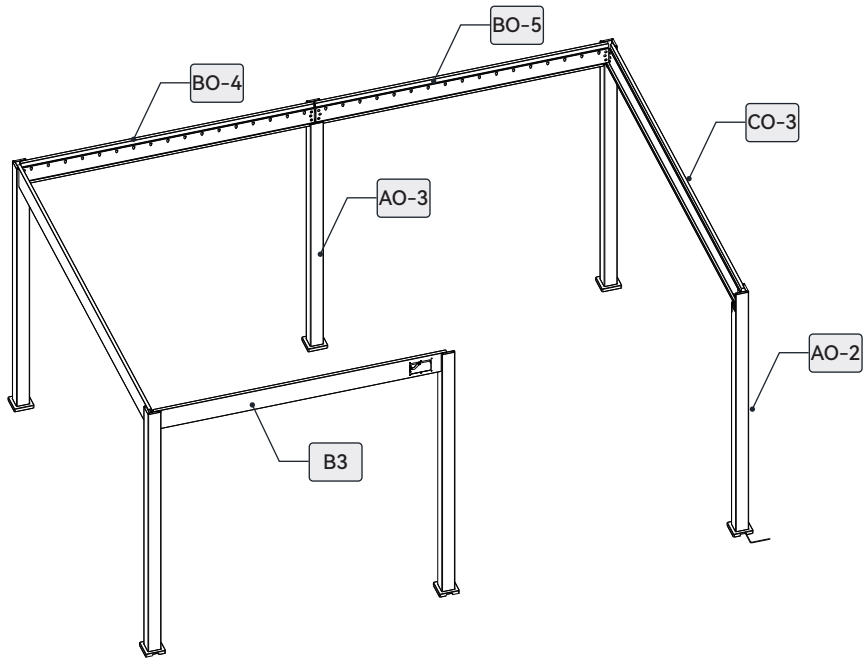

Attention:

Please fasten the screw by hand after installing these screws.

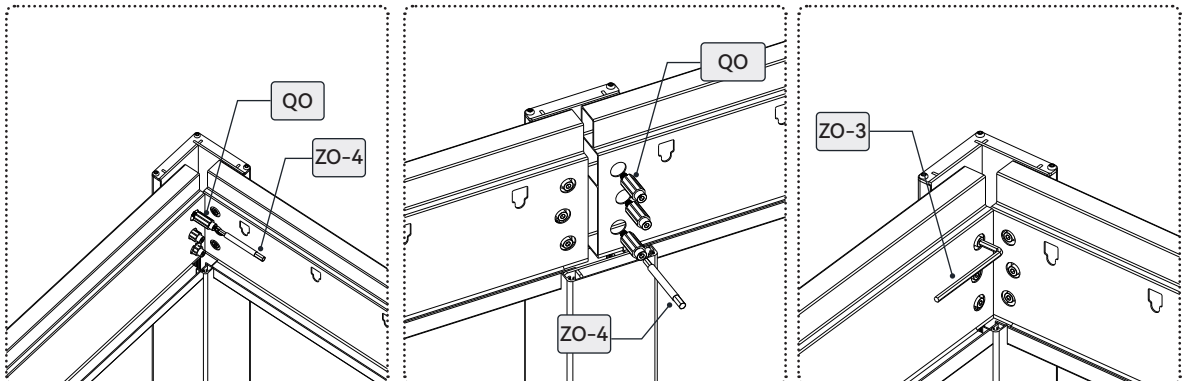



3.6X7.2 ELE & LED

ASSEMBLY GUIDELINES

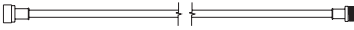
According to the diagram, use an extension cord to connect the motor and complete the connection of the controller wiring within the newly installed main beam.

B4		1
E-E		1

QO			6
----	---	---	---

ZO-1		4mm
ZO-2		4mm

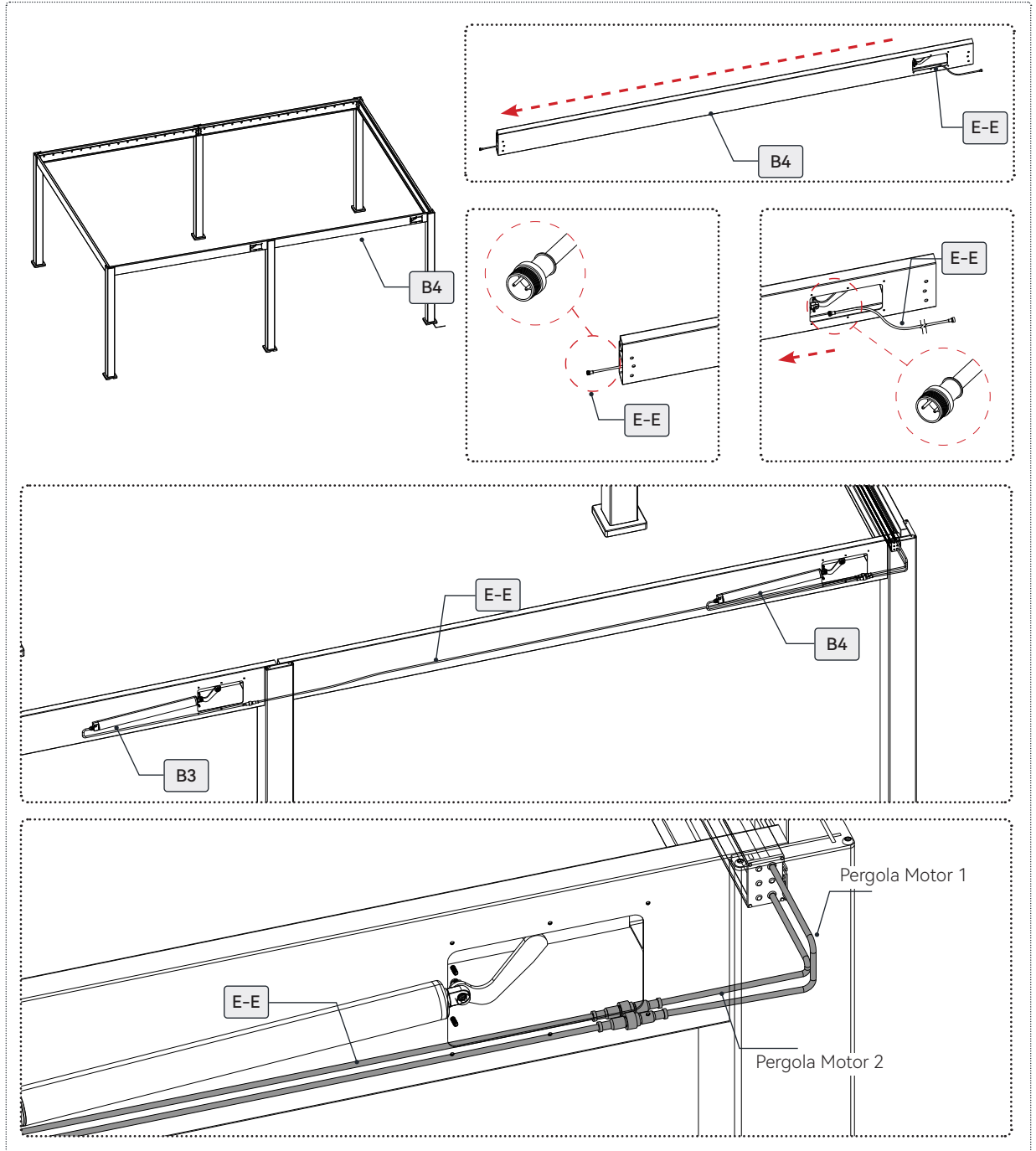



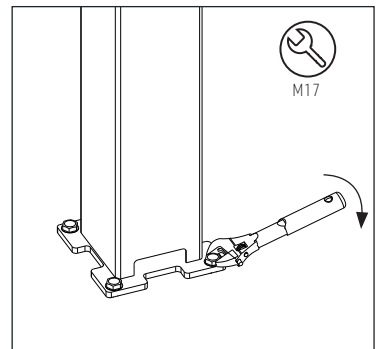
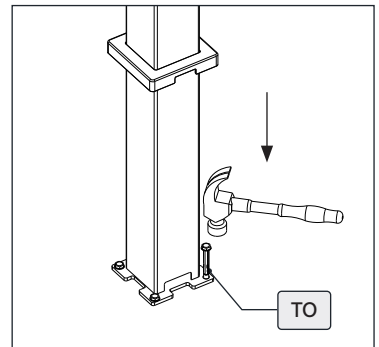
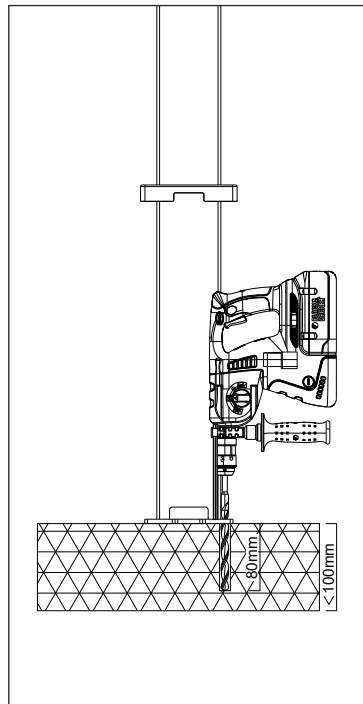
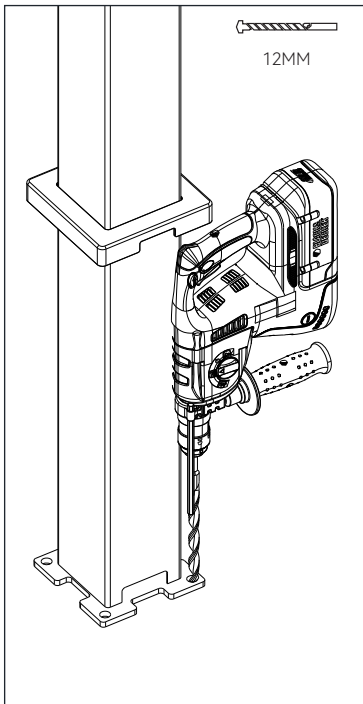
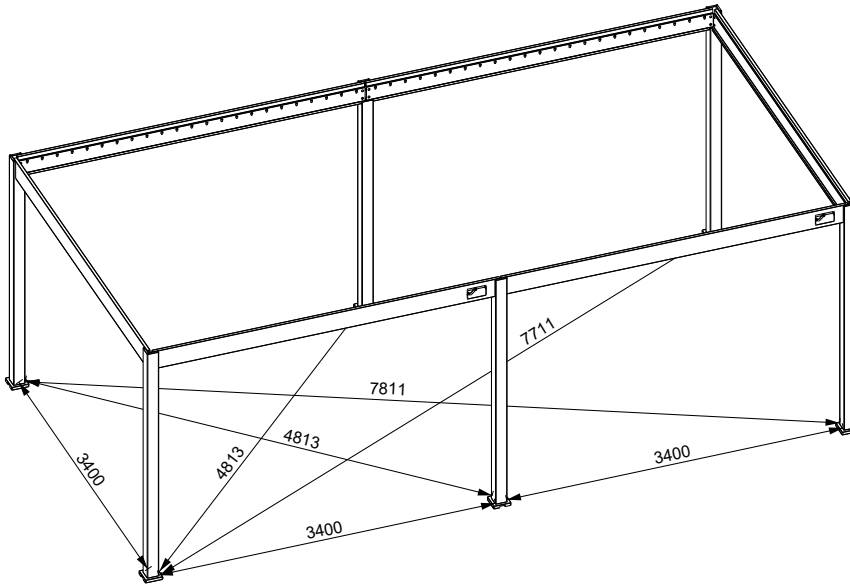

1. Check the dimensions as shown in the diagram.
2. Use a spirit level to ensure that all beams are level and that the posts are at a 90° angle to the ground.
3. Check the vertical alignment of the posts. 4. Adjust the lower edge of the columns according to the dimensions in the diagram.
5. Use a 12 mm hammer drill to drill the holes, then insert the expansion bolts and tighten them with an M17 wrench.

TO	 10x80	24
----	---	----



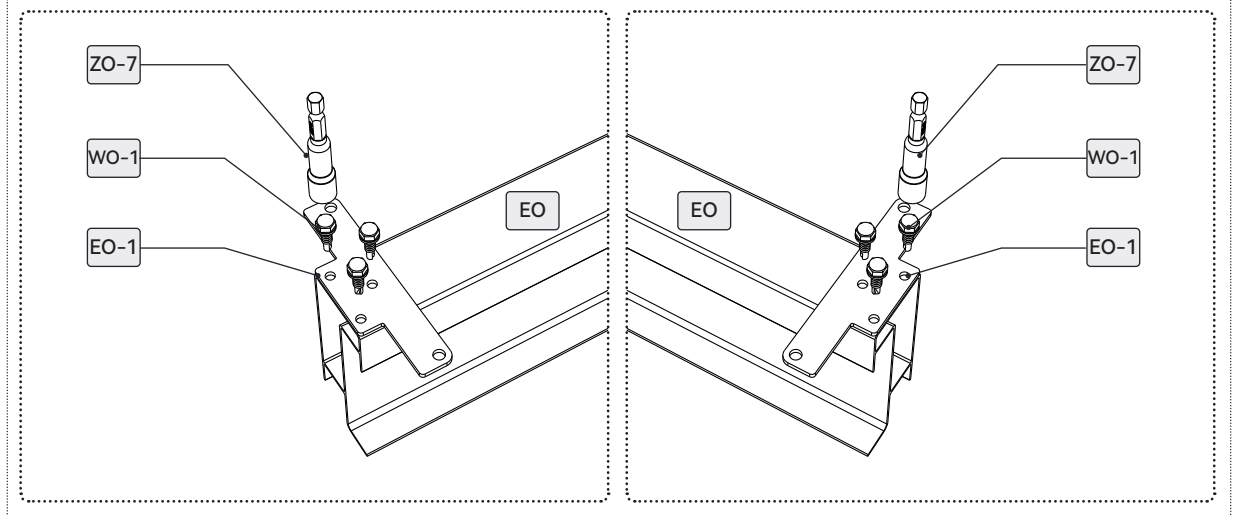
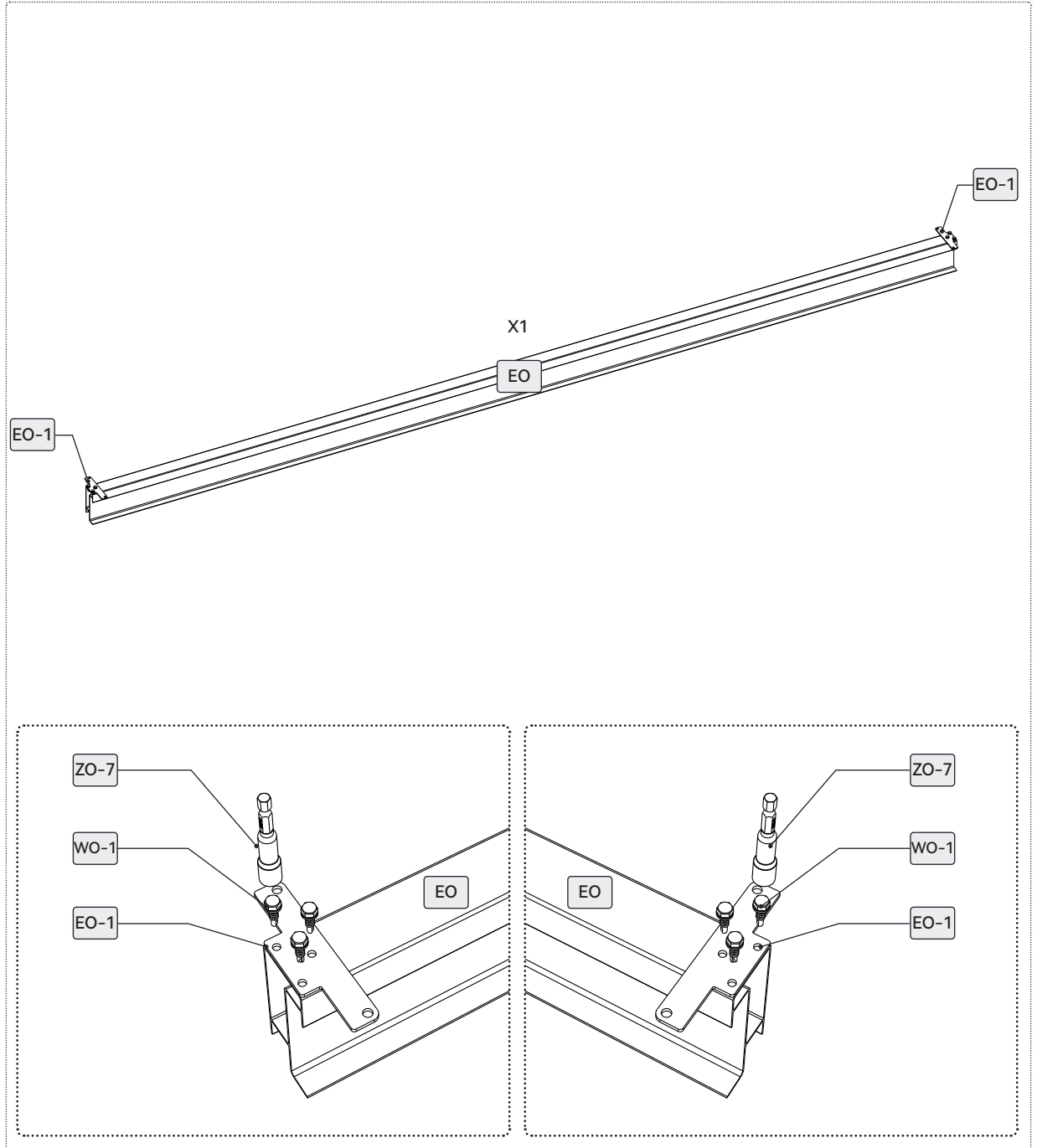

Position, secure, and align the intermediate beam cover plate using provided screws for a stable and seamless finish.

EO		1	EO-1		2	ZO-7	
			WO-1		6		
							



Secure the intermediate beam to the intermediate column using provided fasteners, ensuring proper alignment, stability, and correct placement of the beam.

XO-3	 6x16	 4mm	4
------	--	---	---

ZO-1	 4mm
ZO-2	 4mm

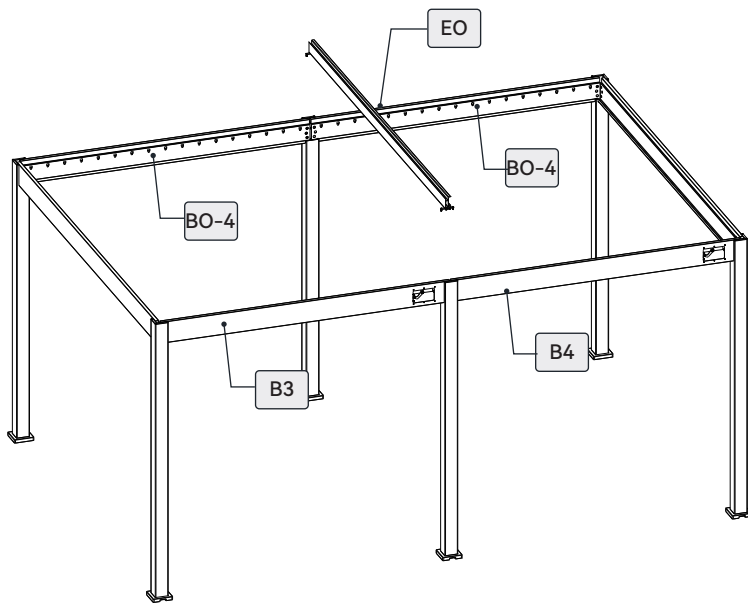

Attention:

It is required to position the intermediate beam as indicated in the diagram.

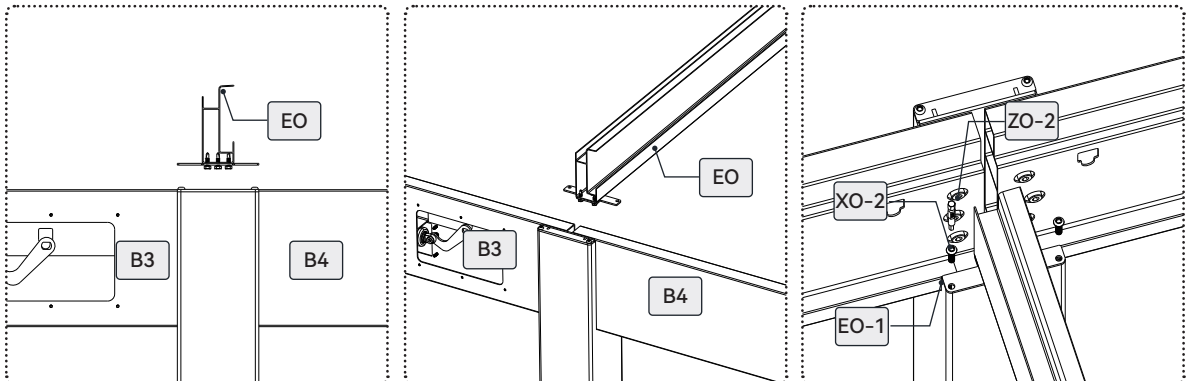

Place the external light strip, connect it to the controller, and link them together in series.

LED1		6
------	---	---

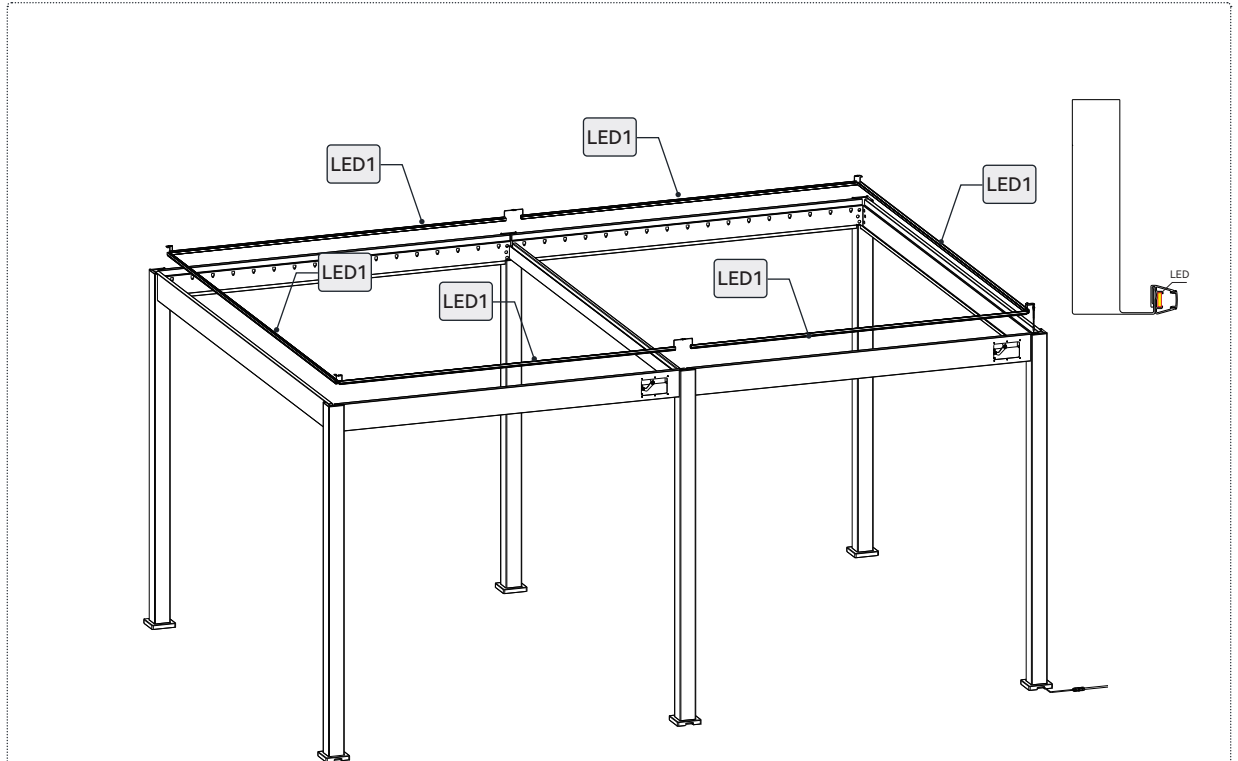

Attention:

Interconnect the LED strips and connect one segment to the controller's LED terminal. After completing connections, securely route the cables into the drainage port.

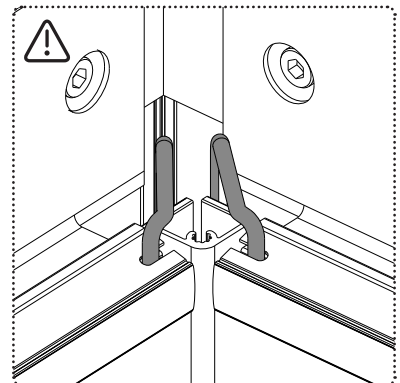
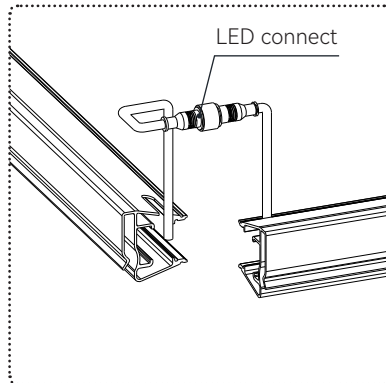
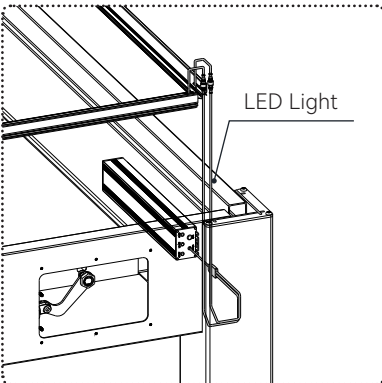

Install the main shaft louvers and secure them using screws. Ensure that the louvers are level.

UO-3	 M14	2
------	---	---

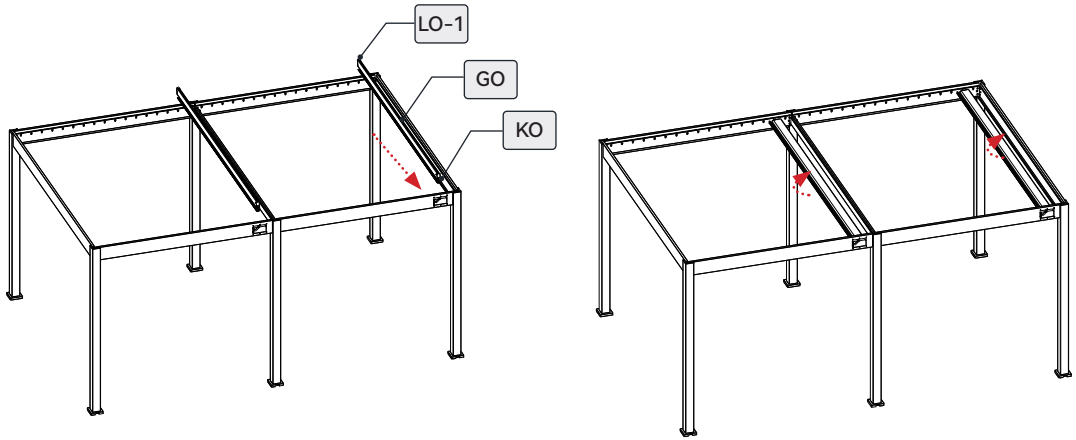

Attention:

Tighten using a wrench.

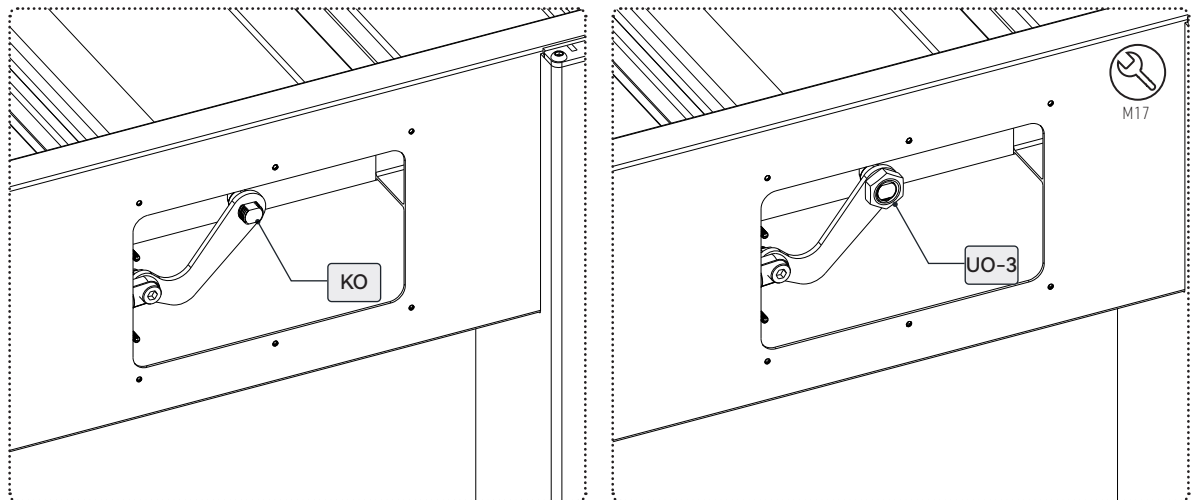

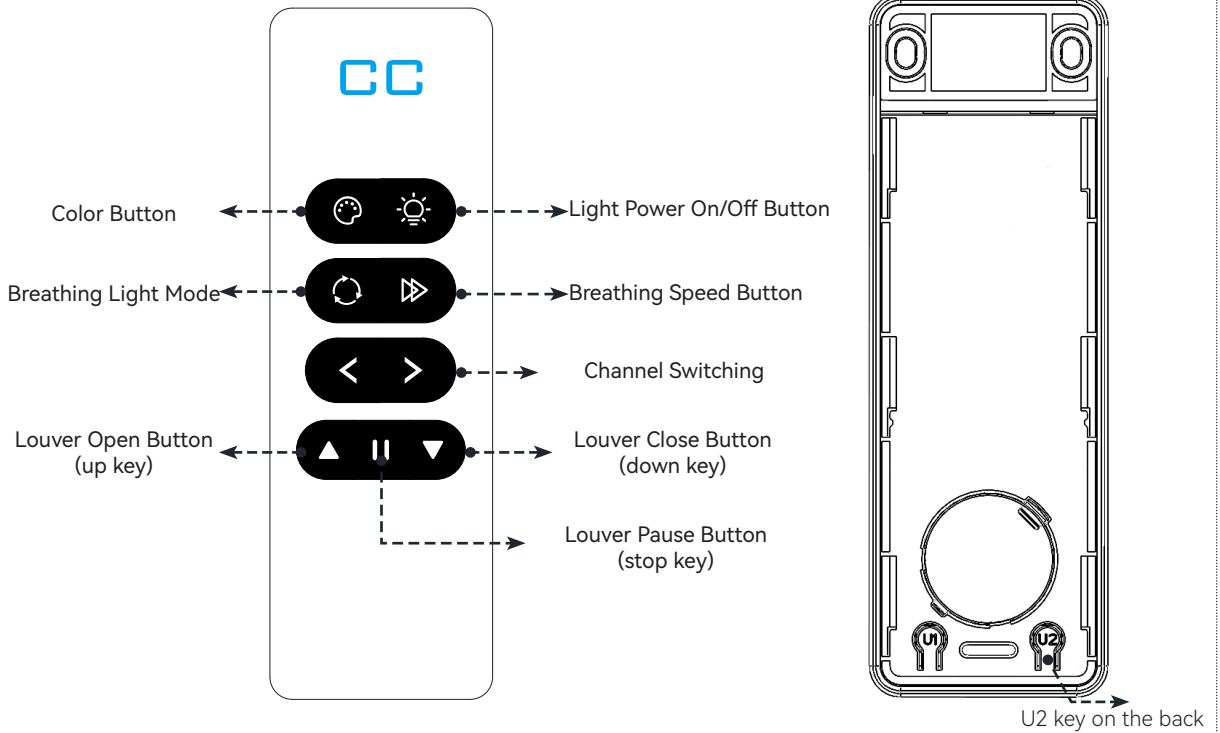

Motor Function:

Use channel selection to choose the desired control mode:

- Channel 1:** Controls the rotation of Louver 1.
- Channel 2:** Controls the rotation of Louver 2.
- Channel CC:** Controls all louvers simultaneously.

This allows for flexible and precise control over individual or grouped louvers based on the selected channel.

RGB Lighting Function

Light Power Button Function:

- Short Press: Cycle control for turning the light on/off.
- Long Press (2 seconds): Cycle dimming for brightness, gradually dimming and brightening.

Color Button Function:

- Short Press: Cycle through 8 color modes: red, green, blue, yellow, cyan, purple, white, and automatic color changing.
- Long Press (2 seconds): Gradual color cycling and color adjustment.

RGB Lighting Breathing Function

Short press the "**Breathing Light Mode Button**": Toggle between turning the breathing mode on and off.

Short press the "**Breathing Speed Button**": Cycle through 5 levels of breathing speed, where the LED light's brightness gradually fades in and out at a faster or slower rate.

This functionality allows for dynamic control over the breathing effect, enabling users to adjust the speed of the light's pulsation to their preference.

Energize the pergola and manipulate the remote control to rotate the shutters to a 90-degree position, thereby facilitating the subsequent installation of additional shutters.

E-BR		1
------	---	---

Install the battery (purchase separately) into the remote control (E-CR) Tip. The battery model we suggest is CR2450.



- 1.The remote control has been pre-paired at the factory and is ready for immediate use.
- 2.If the remote control is not functioning, first check whether the power is turned on and if the indicator light on the remote control is illuminated.
- 3.If no issues are detected during the above checks, follow the steps below to re-pair the remote control:

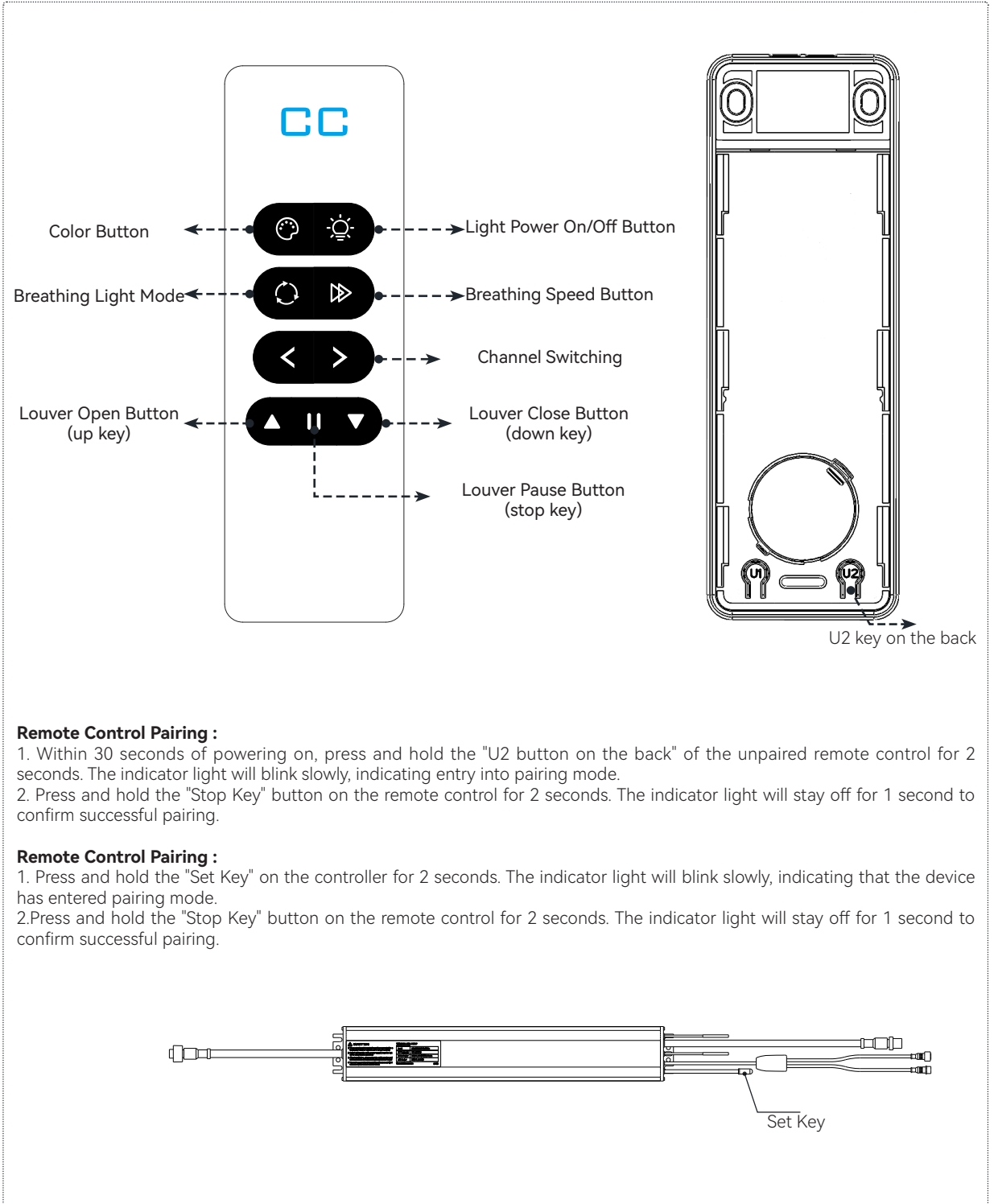

Remote Control Pairing :

1. Within 30 seconds of powering on, press and hold the "U2 button on the back" of the unpaired remote control for 2 seconds. The indicator light will blink slowly, indicating entry into pairing mode.
2. Press and hold the "Stop Key" button on the remote control for 2 seconds. The indicator light will stay off for 1 second to confirm successful pairing.

Remote Control Pairing :

1. Press and hold the "Set Key" on the controller for 2 seconds. The indicator light will blink slowly, indicating that the device has entered pairing mode.
- 2.Press and hold the "Stop Key" button on the remote control for 2 seconds. The indicator light will stay off for 1 second to confirm successful pairing.

The product also supports the TUYA function. The product can be controlled by downloading TUYA. The user must use this function when the WIFI signal is sufficient.

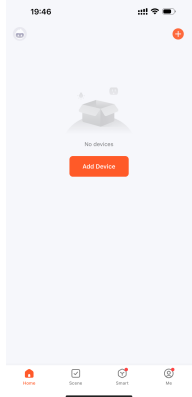

Press 'Add Device'

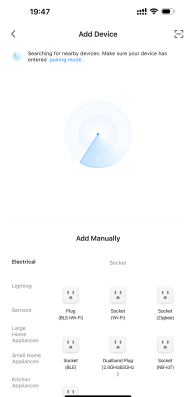

The program start searching for nearby applications automatically which will take for a while.

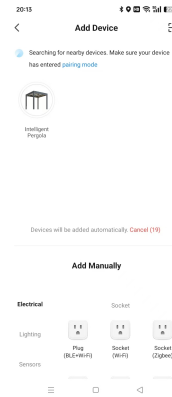

You will find the Intelligent Pergola press.

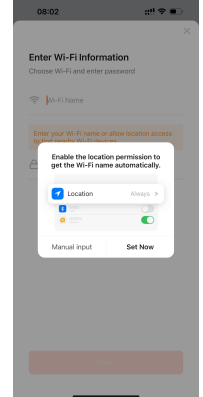

Press 'Set Now' and 'Always allowed'



If you cannot find the corresponding APP in Tuya, please reset the controller's network settings according to the instructions below the diagram.

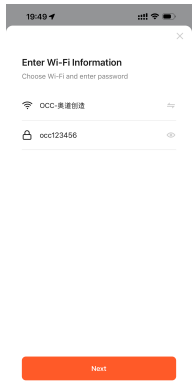

Select your WIFI and input Password.

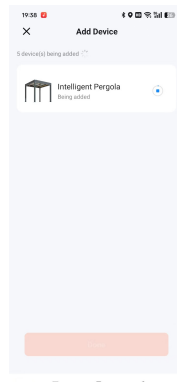

You will see the Intelligent Pergola light connected to you apps.

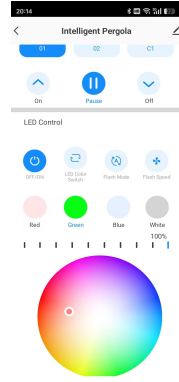

Press the Icon then you will be able to use.

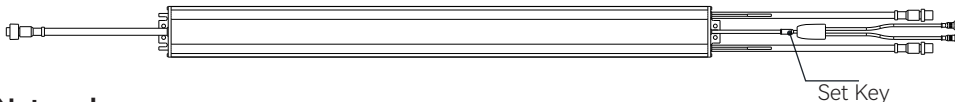

Reset Network:

Method 1:

Long press the "SET Y" on the controller for 7 seconds.

The indicator light will stay off for 1 second, indicating that the network has been successfully cleared.

Method 2:

Long press the "U2 KEY" on the back of the remote control for 2 seconds.

The indicator light will blink slowly, indicating that it has entered the learning mode.

Then, long press the "DOWN KEY" on the remote control for 2 seconds.





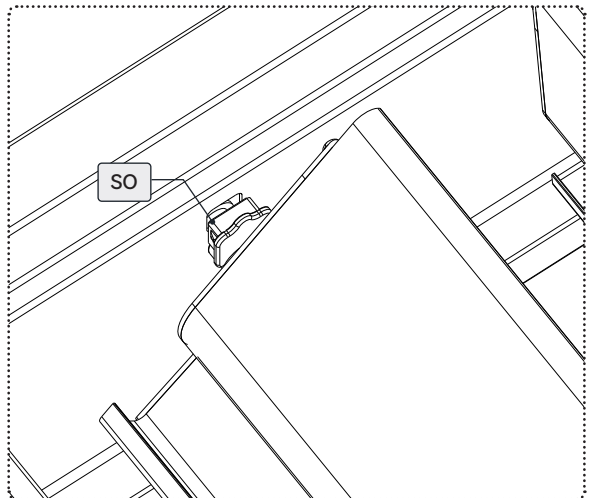
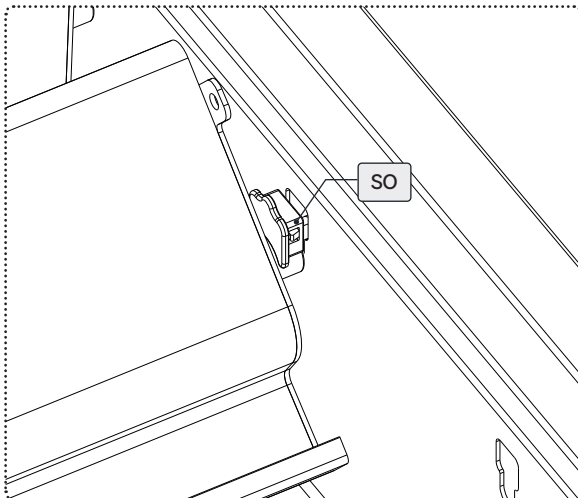
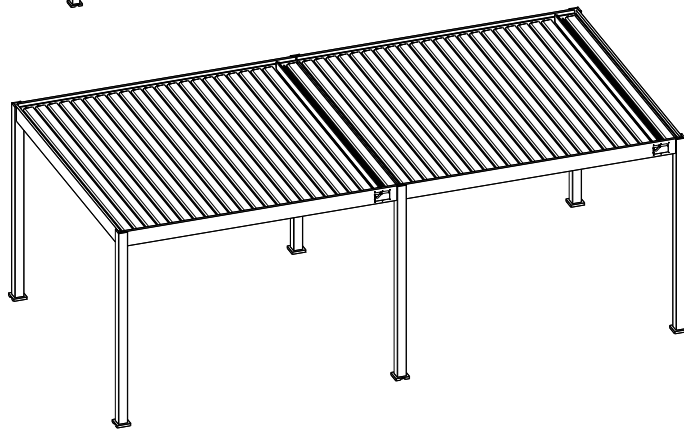
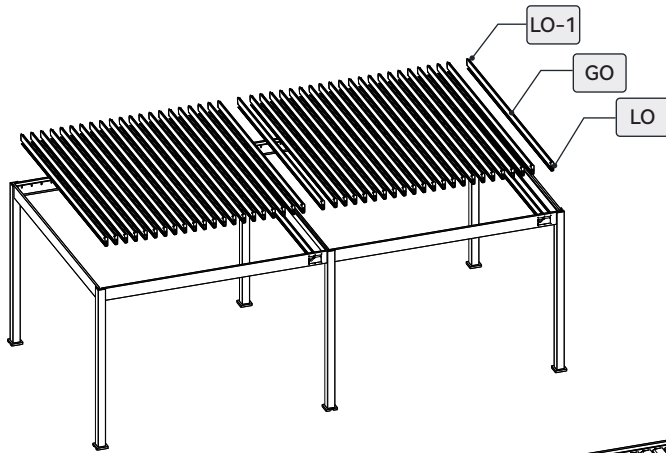



The indicator light will stay off for 1 second, indicating that the network has been successfully cleared.

Install the louver for the pergola and attach the end caps on both sides.



Complete the connection of the connecting rod:

1. After assembling the metal locknut "uO" the "XO-2" screw must have a remaining thread protrusion of 2 mm.
2. The "XO-2" screw should remain movable after the full installation of the drive rail "FO."
3. Test the freedom of movement using the Allen key "ZO-1."

FO		2	XO-2			46	UO		46	ZO-1		4mm
							UO-1		46	ZO-2		4mm
							VO		138	ZO-5		10mm

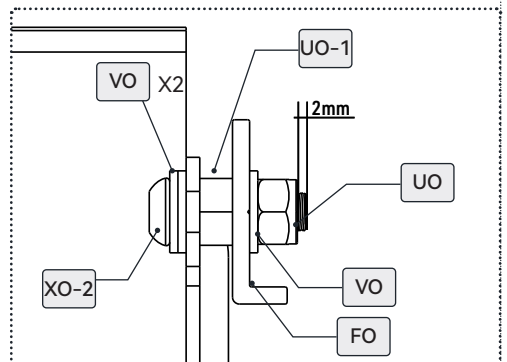
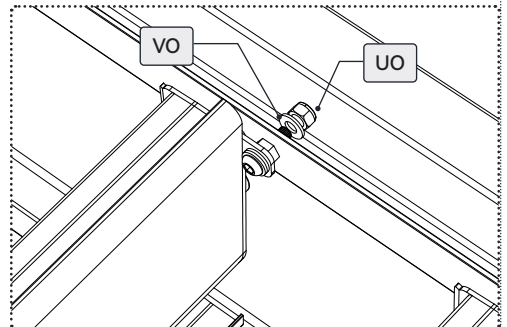
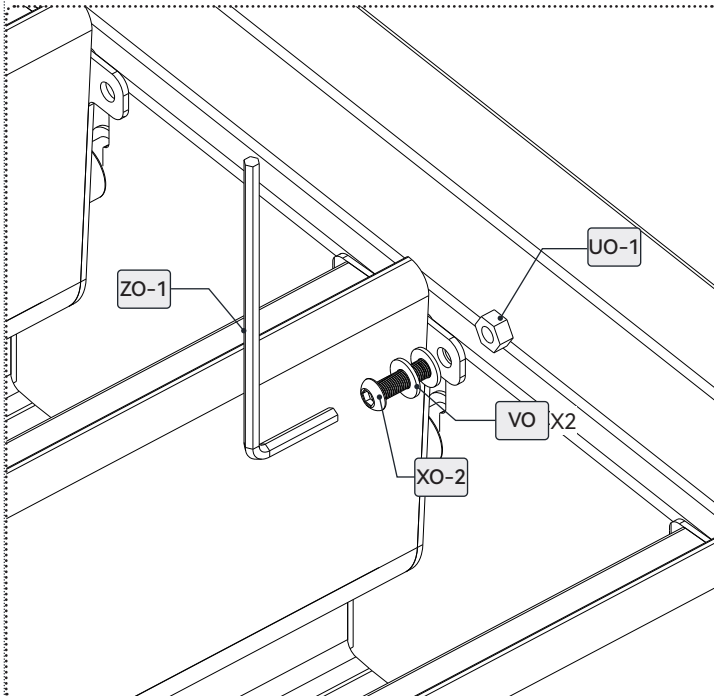
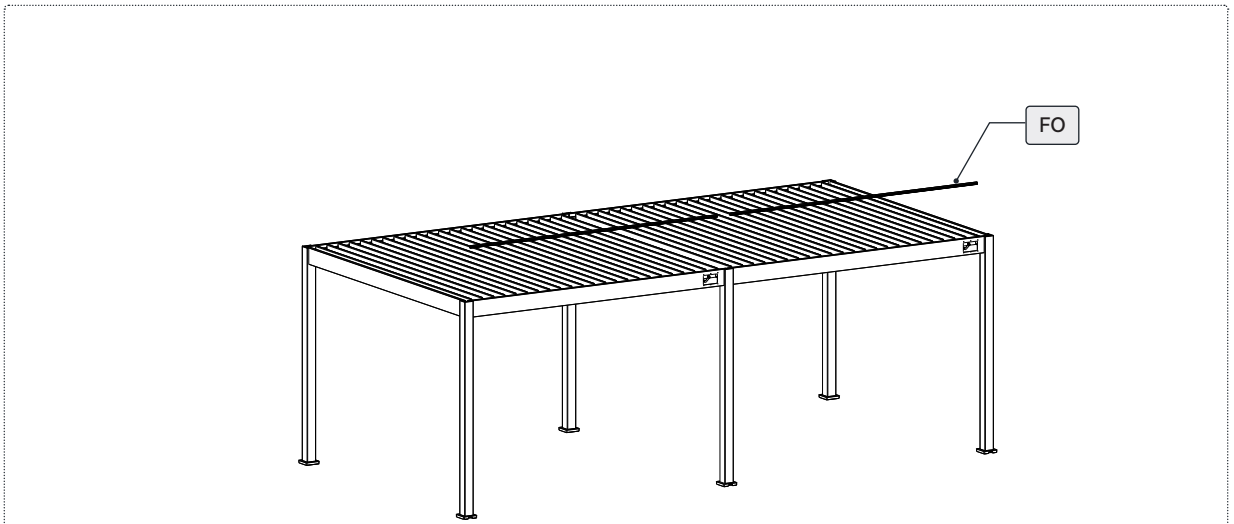

1. Before completing the installation, a function test of the slats is recommended. This helps to identify any damage that may not be visible to the naked eye.
2. Close the slats and ensure that they slide smoothly into each other. There should be no contact, misalignment, or scraping noises between the slats.
3. Install the cover plate and the cap.

RO		36
----	---	----

ZO-6	 PH2
------	--

